

See V1K Installation Guide For Terminal Wire Size And Torque Information.

Note: Maintain Clearance of 3 Inches On All Sides To Other Equipment.

Suggested Customer Entrance (Bottom Entry)

Suggested Customer Entrance (Either Side)

(0.38-16, Ground Stud.)

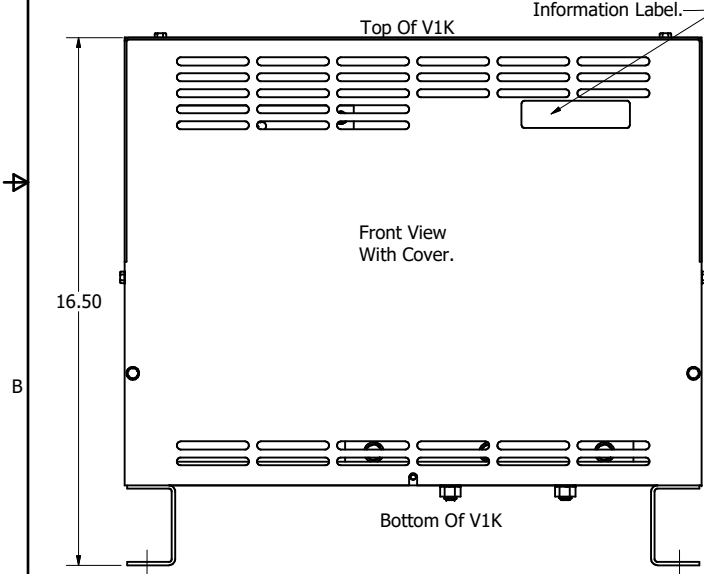

0.41 Dia Mounting Holes  
4 Places.

(Customer Connections)  
Markings On Coil  
For Reference Only.

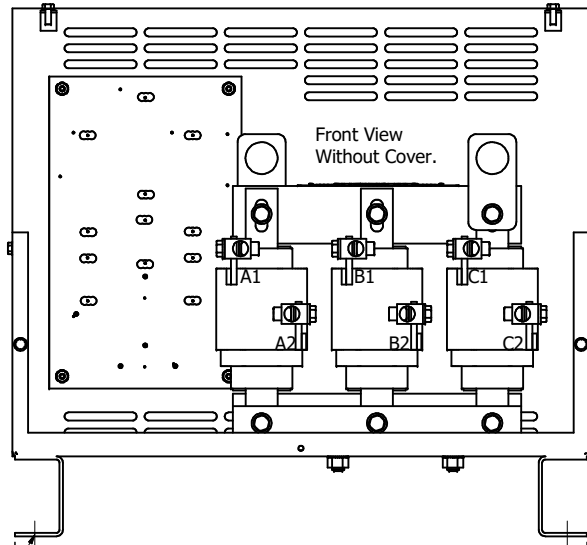

V1K Part Number	Max Voltage	Amps	Phase	Weight (LBS)
V1K130A01*	600	130	3	75
V1K130A01EX*	600	130	3	75

\* = (Blank) - No Thermal Switch  
\* = T - Thermal Switch Option

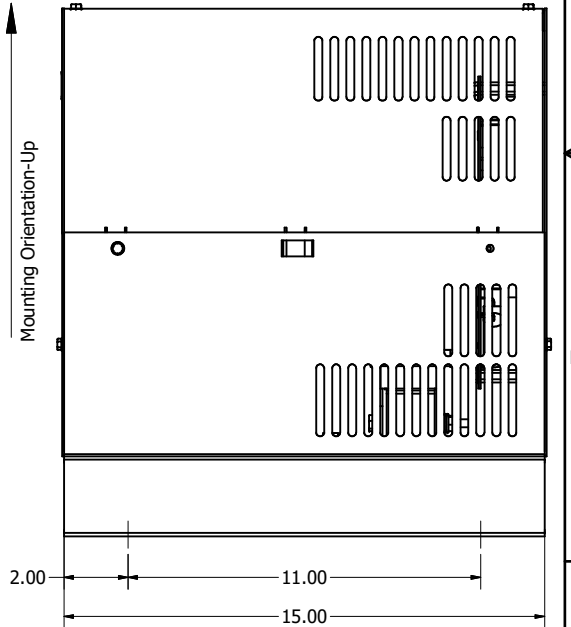
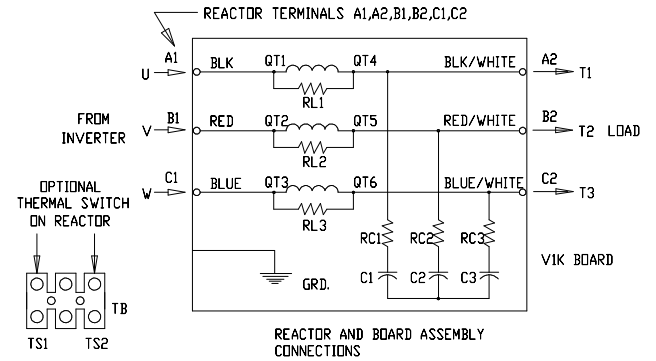

Customer Is Responsible For Installation to Meet All National And Local Electrical Codes.

Material(s) Shall be RoHS Compliant

THE INFORMATION AND DESIGNS CONTAINED IN THIS DRAWING ARE CONFIDENTIAL AND THE PROPRIETARY PROPERTY OF ALLIED MOTION TECHNOLOGIES INC. AND ITS SUBSIDIARIES. NEITHER THIS DESIGN NOR ANY INFORMATION CONTAINED IN THIS DRAWING MAY BE REPRODUCED OR DISCLOSED TO OTHERS WITHOUT THE EXPRESS WRITTEN CONSENT OF ALLIED MOTION TECHNOLOGIES INC. AND ITS SUBSIDIARIES.				TOLERANCES (EXCEPT AS NOTED) DECIMAL .XX ± .25 .XXX ± .10		 W132N10611 (Rev 13 Feb) Germantown, WI 53022 © 2024 TCI, LLC	
H	6535 Termination to 32766	2/14/2024					
G	6391, Iductor Updated	8/25/2023	DSW				
F	4658 Rated To Max Voltage	08/28/20	JRN		FRACTIONAL ± 1/32		
E	4030, Combine, Update V1K Drawings	6/23/17	DSW		ANGULAR ± 1°		
NO	REVISION	DATE	BY				
				DRN BY: DSW	DATE: 4/26/17	102408DG	
				SCALE: TO FIT	DRWN: DSW	REV: 1	SHT 1 OF 1